

MASS-STREAM™

Digital Mass Flow Meters and Controllers for Gases



MASS-STREAM™

Your best choice for inline flow measurement

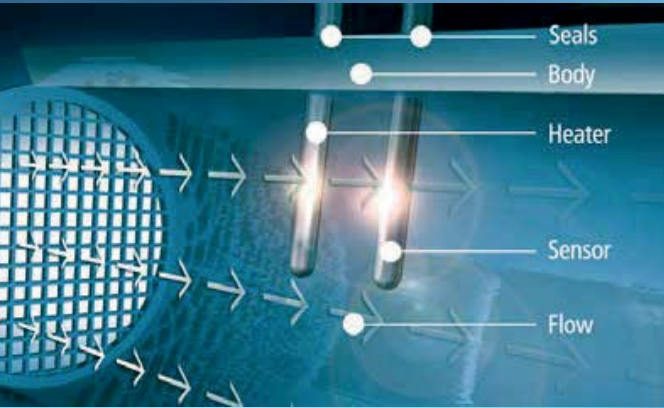

Features

- ◆ Direct inline measurement principle
- ◆ Usable for virtually every kind of gas or gas-mix
- ◆ Mass flow measurement and control for a wide scope of applications
- ◆ Digital pc-board with additional interfaces for DeviceNet™, PROFIBUS DP, Modbus-RTU and FLOW-BUS
- ◆ Precise control mode and good response times
- ◆ Compact and robust design
- ◆ IP65 for full product range
- ◆ Bodies available in aluminium and stainless steel (AISI 316) for corrosive gases
- ◆ Sensor made of stainless steel
- ◆ Low sensitivity to dirt and humidity
- ◆ No inlet pipe required
- ◆ Measurement without moving parts
- ◆ Modern multi-coloured TFT display
 - ◆ IP65 compliant
 - ◆ Operator buttons on the instrument
 - ◆ Customized adjustable multi-functional display: actual flow, totalizer with memory and reset, alarm, setup and much more

Applications

- ◆ Measurement and control technology
- ◆ Aeration
- ◆ Analytical instruments
- ◆ Biogas applications
- ◆ Burner / furnace controls
- ◆ Coating plants
- ◆ Exhaust gas measurement
- ◆ Gas consumption measurement
- ◆ Gas monitoring systems
- ◆ Gas purging
- ◆ Mechanical engineering
- ◆ N₂/O₂-generators
- ◆ Paint-spray lines
- ◆ and much more

Introduction

The thermal Bronkhorst® mass flow meters and controllers for gases on the basis of direct through-flow measurement are produced in Germany since 1997. The MASS-STREAM™ series D-6300 works following the constant temperature anemometer principle. Having benefitted from continuous performance enhancements this through-flow technique can now be also applied to lower flow ranges, which were previously mainly covered by instruments with by-pass measurement technique.

Our MASS-STREAM™ instruments cover a wide range of measurement and control applications in almost every industry sector - like mechanical engineering and process industry, gas production, food and beverage industry as well as environmental engineering and the chemical industry. We are committed to a long lasting cooperation with our customers and of course we are also your competent contact for special solutions. You benefit from our well-trained, highly motivated team and our culture of quality.

Our worldwide sales is mainly covered by our close cooperation with more than 40 sales partners. Please visit our website www.bronkhorst.com for the contact data of your local sales partner.

Flow ranges

Smallest standard range

- ◆ 0.01...0.2 l_n/min (Air)

Highest standard range

- ◆ 200...10000 l_n/min (Air)

Within the above mentioned borders intermediate calibrations with a turn-down ratio up to 1:100 are also possible. In addition Bronkhorst® supplies a wide range of instruments with smaller and higher flow ranges as well as extended standards and tailor-made special solutions.

Principle of through-flow measurement

The mass flow meters and controllers consist of a metal body with a straight through-flow path. Two sensors are encased with stainless steel and protrude inside this bore; one is designed as a heater and the other one is designed as a temperature probe. A constant difference in temperature (ΔT) is created between the two sensors. The heater energy required to maintain this ΔT is dependent on the mass flow. The working principle is based on King's law of the ratio between the mass flow and the heater energy. That means the higher the flow, the more energy is required to maintain the chosen ΔT .

Modern multi-coloured TFT display

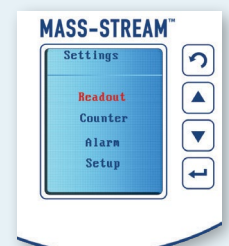

Mass flow meter (MFM) D-63x0

Mass flow controller (MFC) D-63x1, D-63x3



> Principle of operation

The digital MASS-STREAM™ mass flow meters and controllers are operated with a main-board with all functions for the flow measurement and control. The instruments can be supplied with commonly used digital or analogue input/output signals and when ordering a digital instrument please forward the required presets. Along with the standard RS232 interface the additional interfaces DeviceNet™, PROFIBUS DP, Modbus-RTU and FLOW-BUS are also available.

The digital MASS-STREAM™ model series is characterized by a high degree of signal integrity and, as an option, up to 8 calibration curves of different gases and process conditions can be memorized in the instrument.

To provide adaptability and flexibility for a wide range of different process conditions our customers are offered the possibility to adjust, to optimize and to evaluate the parameters and control characteristics, even whilst on site.

The accompanying software is a basic part of our scope of supply of digital mass flow meters and controllers, as well as the calibration certificate, the 8-pin DIN connector for the electrical connection and the software and documentation on CD.

The MASS-STREAM™ mass flow controllers are delivered as compact control units up to flows of 1.000 l_n/min Air-equivalent, with the modular constructed solenoid valve integrated onto the body. Higher gas flows > 1.000 l_n/min Air-equivalent are controlled with mechanically connected separate valves and K_v-values up to 6,0. (Further special valves and combinations on request.)

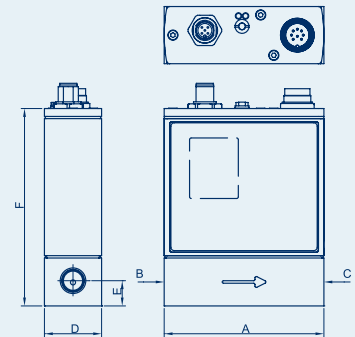

Model D-6310, D-6311, D-6320, D-6321, D-6340, D-6341, D-6360, D-6361

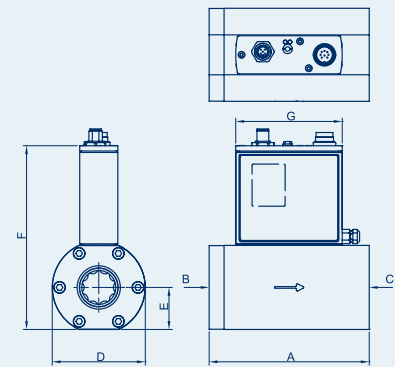

Model D-6370, D-6380

> D-6300 dimensions (in mm)

Model	A	B	C	D	E	F	G	H	I
D-6310	95	G1/4"	G1/4"	34	15	117	95		
D-6320	95	G1/4"	G1/4"	34	15	117	95		
D-6340	95	G1/4"	G1/4"	34	15	114	95		
D-6360	95	G1/2"	G1/2"	34	16	122	95		
D-6370	117	G1/2"	G1/2"	58	25	136	95		
D-6380	143	G1"	G1"	83	37,5	164	95		
D-6390	211	G2"	G2"	120	56,3	201	95		
D-6311	95	G1/4"	G1/4"	34	15	117	95		
D-6321	95	G1/4"	G1/4"	34	15	117	95		
D-6341	95	G1/4"	G1/4"	34	15	114	95		
D-6361	110	G1/2"	G1/2"	34	16	122	95		
D-6371	110	G1/2"	G1/2"	65	25	136	95	10	175

Dimensions for D-6373 and D-6383 on request.

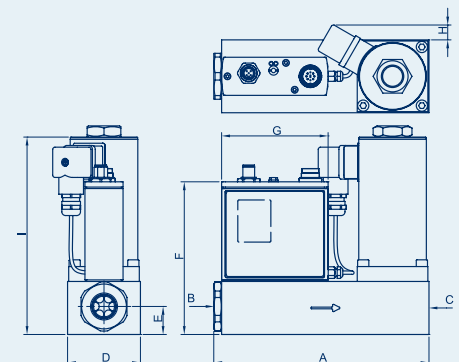

Model D-6371

Standard measurement ranges

Mass flow meter Model	Flow ranges (Air)	intermediate ranges are available
D-6310 - Hxx - BB - xx - 99 - x - S - Dx	Min. 0,01 ... 0,2 l _v /min Max. 0,1 ... 2,0 l _v /min	
D-6320 - Hxx - BB - xx - 99 - x - S - Dx	Min. 0,05 ... 1,0 l _v /min Max. 0,35 ... 7,0 l _v /min	
D-6340 - Hxx - BB - xx - 99 - x - S - Dx	Min. 0,14 ... 7,0 l _v /min Max. 0,5 ... 50,0 l _v /min	
D-6360 - Hxx - CC - xx - 99 - x - S - Dx	Min. 0,4 ... 20,0 l _v /min Max. 2,0 ... 200 l _v /min	
D-6370 - Hxx - CC - xx - 99 - x - S - Dx	Min. 2,0 ... 100 l _v /min Max. 10,0 ... 1.000 l _v /min	
D-6380 - Hxx - DD - xx - 99 - x - S - Dx	Min. 10,0 ... 500 l _v /min Max. 50,0 ... 5.000 l _v /min	
D-6390 - Hxx - FF - xx - 99 - x - S - Dx	Min. 40,0 ... 2.000 l _v /min Max. 200 ... 10.000 l _v /min	
D-6311 - Fxx - BB - xx - 99 - x - S - Dx	Min. 0,01 ... 0,2 l _v /min Max. 0,1 ... 2,0 l _v /min	
D-6321 - Fxx - BB - xx - 99 - x - S - Dx	Min. 0,01 ... 0,2 l _v /min Max. 0,1 ... 2,0 l _v /min	
D-6341 - Fxx - BB - xx - 99 - x - S - Dx	Min. 0,05 ... 1,0 l _v /min Max. 0,35 ... 7,0 l _v /min	
D-6361* - Fxx - CC - xx - 99 - x - S - Dx	Min. 0,4 ... 20,0 l _v /min Max. 4,0 ... 200 l _v /min	
D-6371* - Fxx - CC - xx - 99 - x - S - Dx	Min. 2,0 ... 100 l _v /min Max. 20,0 ... 1.000 l _v /min	
D-6383 - Fxx - DD - xx - 99 - x - S - Dx	Min. 10,0 ... 500 l _v /min Max. 100 ... 5.000 l _v /min	

*Also valid for D-6363 respectively D-6373
Technical changes and alterations in construction are reserved.

Conversion factor

MASS-STREAM™ mass flow meters and controllers are basically calibrated on air. If other gases or gas mixtures are used a conversion factor CF will be applied. This factor is determined by applying a complex formula*. For a number of commonly used gases you will find the value in the adjoining chart.

*The instrument is always calibrated to the customers needs, benefitting from 25 years experience.

Conversion factors ($I_n \hat{=} 1013 \text{ mbar}$ and $0 \text{ }^\circ\text{C}$ air temperature)

Gas	CF D-631x and D-632x	CF D-634x up to D-638x	Gas	CF D-631x and D-632x	CF D-634x up to D-638x
Air	1,00	1,00	CO ₂	0,86	1,13
Ar	1,50	2,02	HCl	1,12	1,53
CH ₄	0,77	0,61	N ₂	1,00	1,00
C ₂ H ₂	0,66	0,68	NH ₃	0,82	0,74
C ₂ H ₄	0,70	0,75	NO	1,00	1,01
C ₂ H ₆	0,58	0,62	N ₂ O	0,83	1,08
C ₃ H ₈	0,43	0,51	O ₂	0,99	0,97
C ₄ H ₁₀	0,32	0,41	Xe	1,96	6,09
CO	1,01	1,04	Other gases on request.		

Please refer to www.fluidat.com

The mentioned values are only regarded as an indication. The exact conversion factors are significantly dependent on the process parameters, like media temperature and operating pressure, and on the physical characteristics of the gas. The best accuracy can be obtained by calibrating the instrument under operating conditions. The conversion factor causes an additional error in the absolute accuracy. With a conversion factor >1 this error is 2 x CF (in % FS) and with a conversion factor <1 this error is 2 / CF (in % FS).

Flow profile and sensitivity

In general mass flow measurement is very sensitive to variations of the shape of the flow profile. The MASS-STREAM™ instruments are designed for a consistent, fully developed flow profile in the metering section. Installing a suitable well-sized inlet pipe is recommended for our robust and concurrent precise mass flow measurement. Without an inlet pipe or insufficient inlet piping conditions severe deviations in the accuracy could possibly occur.

Pressure loss

The pressure drop over the instrument's D-6300 measurement chamber is almost comparable to a straight run of pipe of the same diameter and is thus almost negligible. However, to make the instruments less sensitive to upstream piping configurations (e.g. turbulences, welded joints, elbows) special mesh screens are required to condition the flow profile. These meshes create a certain pressure drop.

Also the often used compression type connections cause a significant additional pressure loss. We recommend to install fittings with maximized internal diameter and offer the use of an inlet pipe as an option.

Enquiry and order information

In order to supply the correct instrument for your application, please submit the following data: type of gas, flow range, operating temperature and pressure (for controllers inlet and back pressure), electrical connection, desired output signal, type of connections (fittings) and seals, analogue or digital presetting. Based on this information, the requested flow will be converted to the Air-equivalent flow (by dividing the requested flow by the referred conversion factor).

► Technical specifications

Measurement system	
Accuracy (at calibration conditions)	$\pm 1,0\%$ RD plus $\pm 0,5\%$ FS
Repeatability	$< \pm 0,2\%$ FS
Pressure sensitivity	$\pm 0,3\%$ RD / bar typical (Air)
Temperature sensitivity	$\pm 0,2\%$ RD / °C (Air)
Attitude sensitivity	at 90° deviation from horizontal max. error 0,2 % at 1 bar typical N ₂
Control stability	$< 0,2\%$ FS typical
External leak integrity	$< 2 \times 10^{-8}$ mbar l/s He
Response time sensor (63 %)	D-631x / D-632x: approx. 0,3 seconds other models: approx. 0,9 seconds
Settling time (controller)	up to approx. 2 seconds (depending on selected valve)
RFI (radio frequency interference)	according to EU declaration

*The calibration of instruments in the lower measurement range and for some gases could result in a reduced accuracy.

Mechanical parts	
Sensor	Stainless steel SS 316 (AISI 316L)
Instrument body	Aluminium AL 505T/51ST (anodised) or stainless steel SS 316
Sieves and rings	Teflon or stainless steel SS 316
Protection	IP65 (with and without display)

Operating limits	
Measuring range (turn-down-ratio)	up to 1...100 % (1:100) for meters up to 2...100 % (1:50) for controllers
Type of gases	almost all gases, compatible with chosen materials
Temperature	0...50 °C
Pressure rating	0...10 bar (g) for instrument body in aluminium, 0...20 bar (g) for instrument body in stainless steel SS 316
Warm-up time	30 minutes for optimum accuracy within 30 seconds for accuracy $\pm 4\%$ FS

Electrical properties	
Supply voltage	+15...24 Vdc $\pm 10\%$ / +24 Vdc for BJ Valve
Current peak values	Meter approx. 75 mA at 0 % flow approx. 125 mA at 100 % flow Controller add 250 mA add 30 mA for display, if applicable add 50 mA for additional interface, if applicable
Output signal	0...10 Vdc / 0...5 Vdc active or 0...20 mA / 4...20 mA active
Connector	8-pin round DIN (male) for analogue and RS 232 additional connectors for interfaces: ◆ 5-pin M12 (male) for DeviceNet™ FLOW-BUS Modbus-RTU ◆ 5-pin M12 (female) for PROFIBUS-DP

Technical changes and alterations in construction are reserved.



> Model number identification

D-63N N - A A A - AA - A - A - 99 - A - S - DA

Base model

D-631	up to 2 l _r /min
D-632	up to 7 l _r /min
D-634	up to 50 l _r /min
D-636	up to 200 l _r /min
D-637	up to 1.000 l _r /min
D-638	up to 5.000 l _r /min
D-639	up to 10.000 l _r /min

Function

0	Meter
1	Controller with integrated valve
3	Controller with port connector and external valve

Design

F	Controller N/C (Valve normally closed)
G	Controller (Normally open)
H	Meter
Z	Other

Input/output signal

A	0 - 5 Vdc
B	0 - 10 Vdc
F	0 - 20 mA
G	4 - 20 mA

Power supply

B	+24 Vdc
D	+15 ... 24 Vdc

Gas connection inlet/outlet

Internal thread

BB	G1/4" (=1/4" BSPP)
CC	G1/2" (=1/2" BSPP)
DD	G1" (=1" BSPP)
FF	G2" (=2" BSPP)

Fittings

11	1/8" compression
22	1/4" compression
33	6 mm compression
44	12 mm compression
55	1/2" compression
66	20 mm compression
88	1/4" VCR
99	Other

Material

A	Aluminium AL 50ST/51ST
S	Stainless steel SS 316

Seals

E	EPDM 559241
K	Kalrez® 6374
V	Viton 1415
Z	individual
VSP	Viton 554278
VSP	EPDM 554241
VSP	Kalrez® 6230

Flow rate for air

99	all gases / flow rates
----	------------------------

Display

0	without display
D	with display

Sensor

S	standard sensor
---	-----------------

Communication

DR	RS 232
DF	FLOW-BUS
DM	Modbus-RTU
DN	DeviceNet™
DP	PROFIBUS DP



For mass flow controllers only:

- ◆ Check if the differential pressure over the valve (ΔP) is within the allowed limits.
- ◆ Check if the calculated K_v -value is within the specification.



Representantes / Distribuidores Exclusivos

Argentina

Tel: (+54 11) 5352 2500

Email: info@dastecsrl.com.ar

Web: www.dastecsrl.com.ar