

SolidFlow 2.0

Solid mass flow measurement

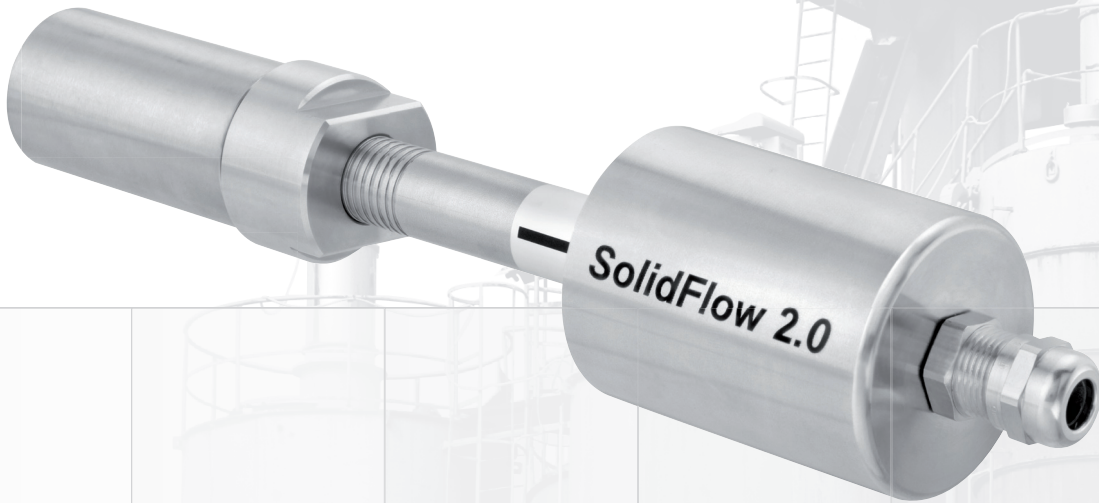

Use

SolidFlow 2.0 has been specially developed for measuring solid volumes conveyed through pipelines.

SolidFlow 2.0 is used for online measuring:

- all types of dust, powder, granulates, etc.
- with particle sizes between 1 nm and 10 mm
- which are conveyed pneumatically
- or in free fall after mechanical conveyor systems

SolidFlow 2.0 is extremely easy to install and has a wear-resistant design.

SolidFlow 2.0 is the latest generation of microwave-based measuring systems for measuring the flow of solids.

Based on our many years of expertise, SWR has developed a second generation version of this sensor.

SolidFlow 2.0 is a reliable sensor which eliminates the disadvantages encountered in current technologies available on the market.

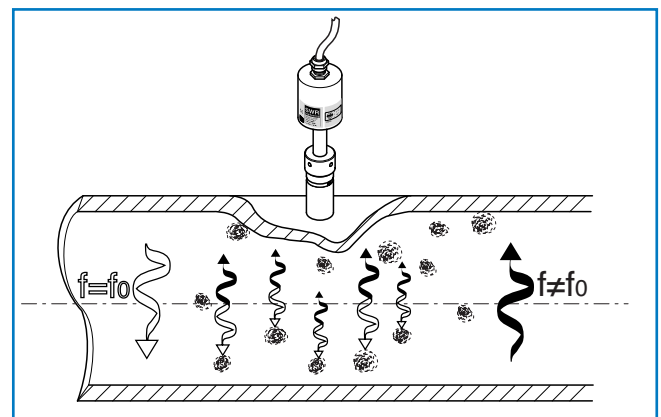

Function

The SolidFlow 2.0 sensor uses the latest microwave technology. The sensor is used exclusively in metal pipelines. The special integration of microwave technology creates the measurement field together with the metal pipeline. The microwave radiation in the pipeline is reflected by the solid particles and received by the sensor.

The frequency and amplitude of the received signals are analysed.

The sensor works like a particle counter, counting the quantity of flowing particles per unit of time. The frequency-selected evaluation system ensures that only flowing particles are measured while deposits are suppressed.

SolidFlow 2.0 features active stratification compensation which compensates measurement errors caused by stratification, in particular while materials are being pneumatically conveyed.

Based on new processing technology, the measurement signal is converted into its frequency spectrum which is used to detect the material's flow pattern. The sensor is calibrated during installation by entering the reference quantity and pressing a button.

The illustrations show two frequency spectra for different flow conditions with similar mass flows. A software algorithm ensures that the measuring result is correct even with different flow conditions.

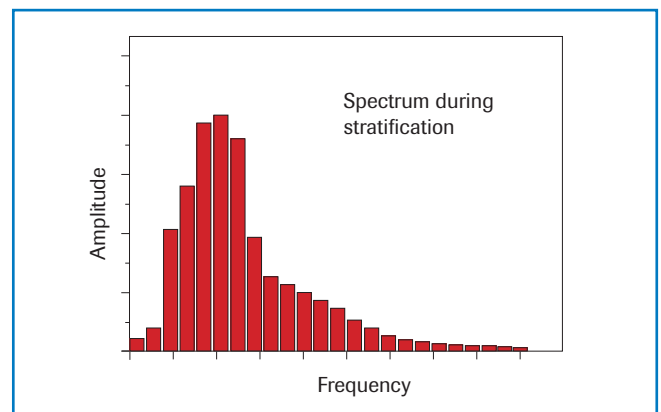
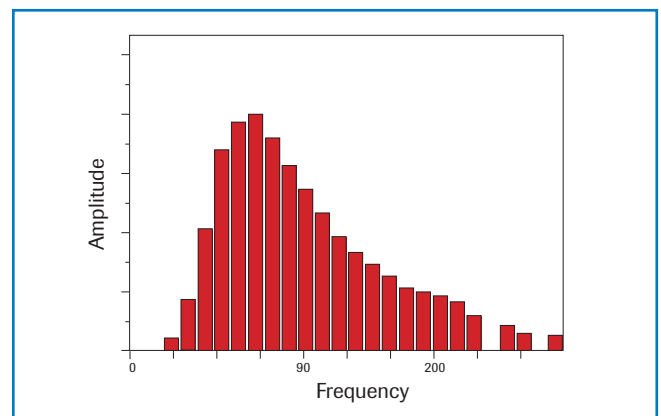

System

A complete measuring point consists of the following components:

- Socket for mounting the sensor, including plugs
- FMS sensor with a 2 meter-connecting cable
- C-Box for connecting the sensor and transmitter
- FME transmitter with a resettable total counter

The transmitter is available as a field enclosure version with touch panel control and a display, or in a DIN rail version. With the DIN rail version, software is supplied for parametrisation purposes.

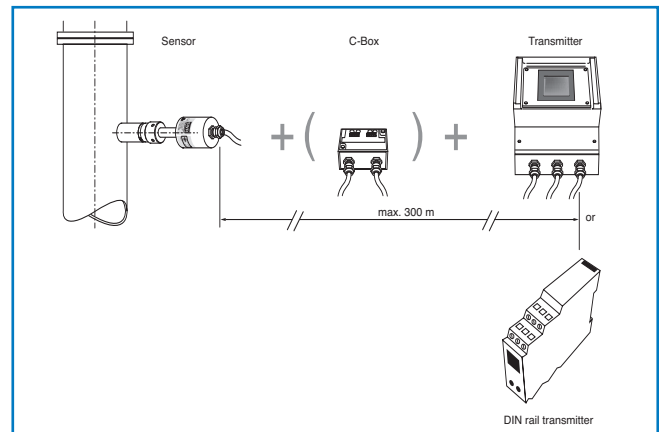

Applications – Practical Examples

▪ Compounding plant

Mixtures are created using the sandwich technique with a weighing container. The existing weighing device was not designed for dosing small quantities of additional components, which meant that measured doses could not be reproduced.

Benefits:

SolidFlow 2.0 enables the dosing of additional components to be reproduced and better balancing of the quantities used.

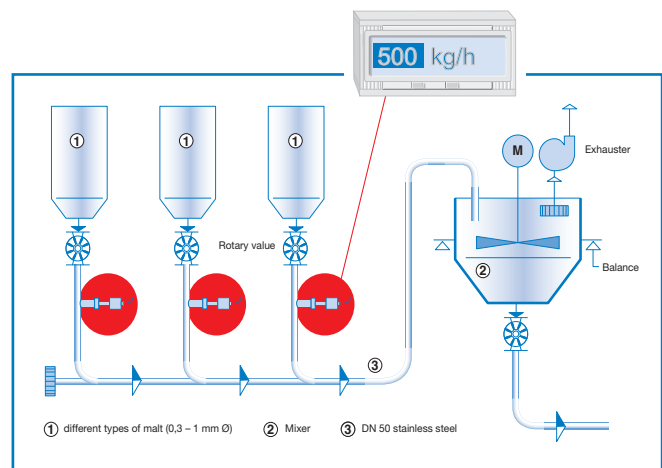

▪ Fuel delivery

In a boiler, dust is conveyed as fuel to the combustion chamber. As there is no information about the distribution of fuel quantities in the different supply lines, setting optimum combustion is not always possible

Benefits:

Each supply line is monitored by a SolidFlow 2.0 system, and the supply of fuel quantities is regulated in each individual supply line. This enables accurate and uniform distribution of fuel quantities which is an essential requirement for optimum combustion.

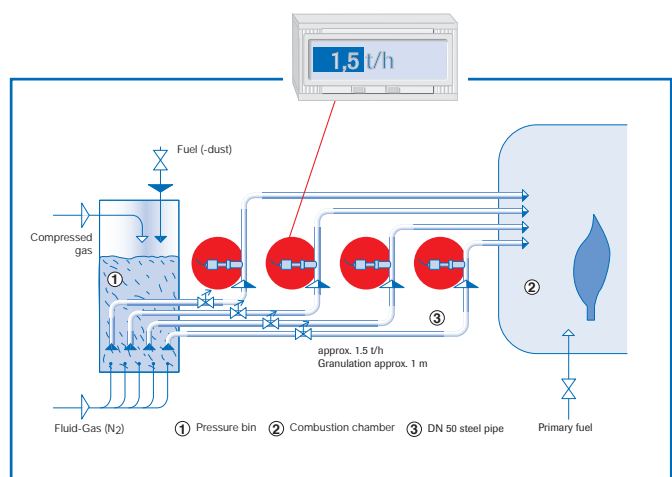

Quantity balancing

The supply of materials to the grinding system is subject to significant fluctuations.

Benefits:

With SolidFlow 2.0, the progress of the mass flow can be measured and documented.

If necessary, adjustments can be made.

By measuring the coarse grain between the grinding system and the mill, the grinding quality can also be monitored.

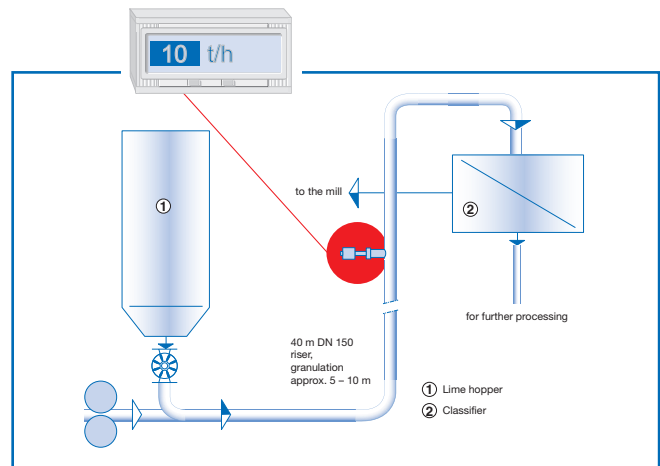

Free-fall application

A belt weigher records the amount of cement conveyed.

This measurement is used as a guide value when metering the addition of iron(II) sulphate.

This must be metered with a proportion of 0.2 ... 0.3 %.

Benefits:

With SolidFlow 2.0, the actual value of the metered iron(II) sulphate is recorded and regulated by adjusting the screw conveyor's speed.

The result is uniform product quality.

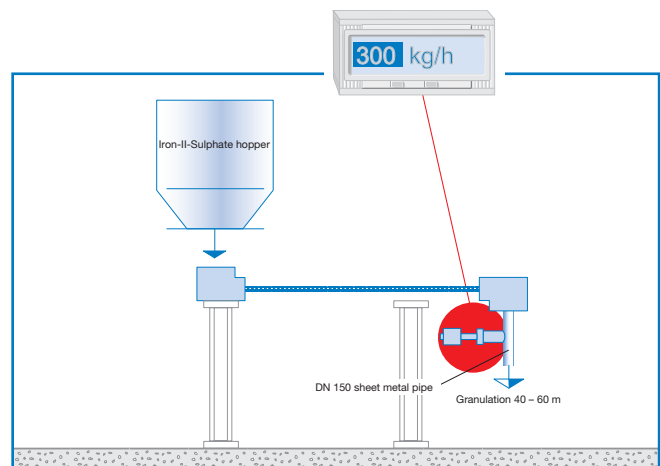

Granulate dosing system

The existing dosing tank is too inaccurate, that means the plant can only operate intermittently.

Benefits:

SolidFlow 2.0 enables transparent monitoring of the conveyed quantities and the process can be turned into one continuous operation.

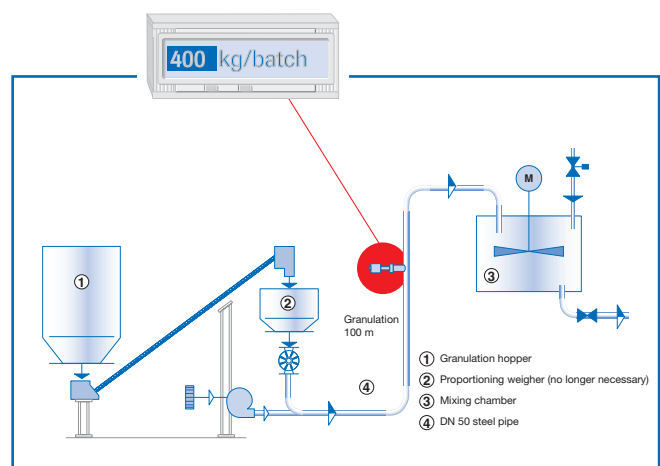

Mounting and installation

To install the sensor, the installation location must be determined according to the required inlet and outlet areas. With pipe diameters larger than 200 mm, 2 or 3 sensors are used per measuring point and the sensors are arranged at angles of 90° or 120° to each other.

In free-fall applications (for example after screw conveyors or rotary feeders), an infeed section (drop height) of at least 300 mm is ideal.

The sensor bracket (welded support) is welded on at the specified installation location. After this, a 20 mm-borehole is drilled through the sensor bracket and through the pipe wall.

The sensor is then adjusted to the wall thickness, inserted and fixed with the aid of union nuts. Done!

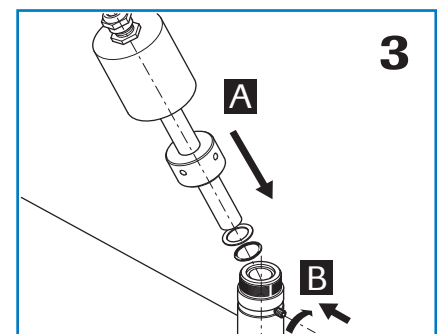
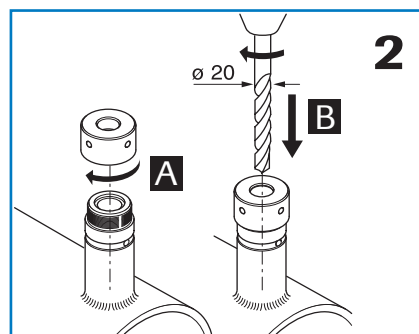
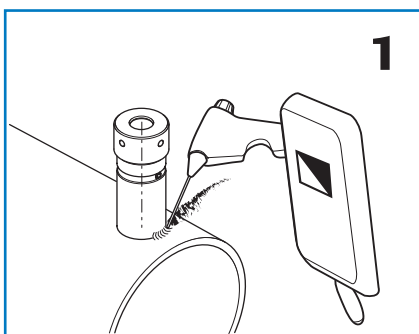
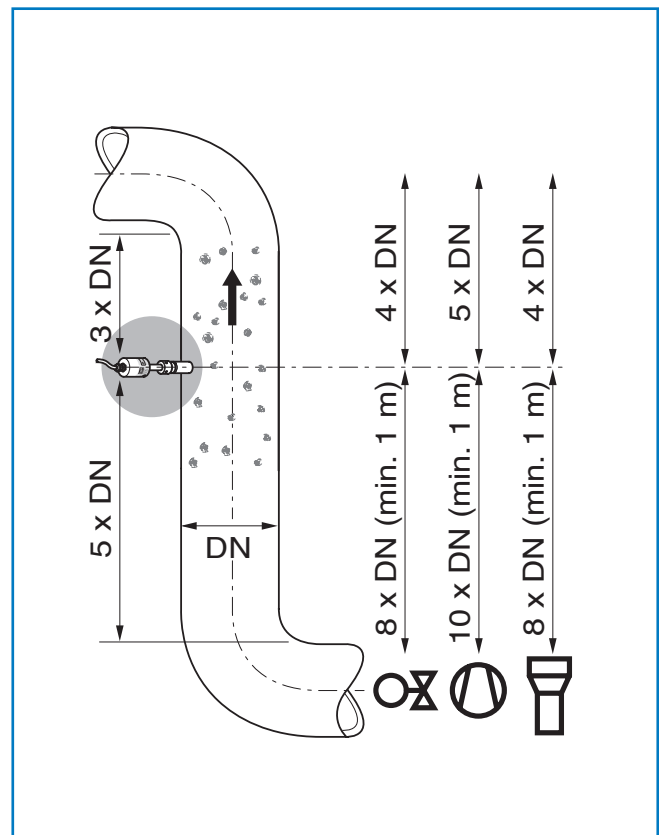
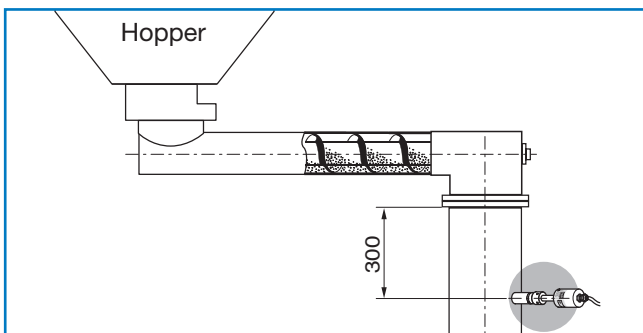

Commissioning

The measuring device is started up by the FME transmitter. This electronic unit enables convenient menu-guided input of parameters such as measuring range, required physical units or measuring signal attenuation. The available outputs are a current output, 4 ... 20 mA and a pulse output (open collector).

The integrated total counter enables easy calibration. The menu language options are German, English or French.

When using DIN rail transmitter, the system is operated via the supplied software.

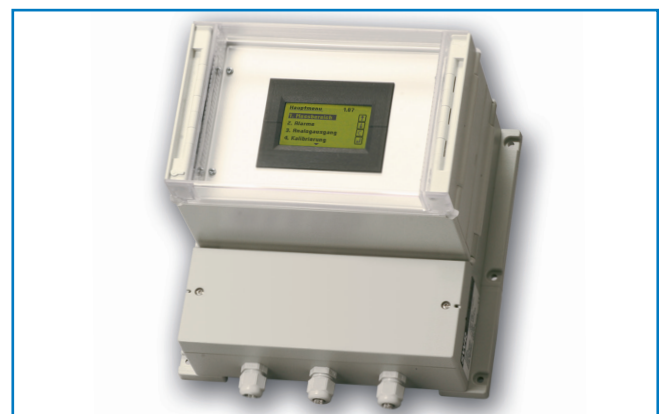

Technical data

| Sensor | |
|-----------------------|--|
| Housing | Stainless steel 1.4571 |
| Protection category | IP 65, DustEx zone 20 or GasEx zone 1 (optional) |
| Operating temperature | Front end of sensor: -20... +80 °C Optional: -20 ... +200 °C Sensor electronic: 0 ... +60 °C |
| Max. working pressure | 1 bar, optional 10 bar |
| Working frequency | K-Band 24.125 GHz, ±100 MHz |
| Transmitting power | Max. 5 mW |
| Weight | 1.3 kg |
| Dimensions | Ø 60, Ø 20, L 271 mm |
| Accuracy | ± 2 ... 5 % in calibrated range |

| Field housing transmitter | |
|--------------------------------------|--|
| Power supply | 110/230 V, 50 Hz (optional 24 V DC) |
| Power consumption | 20 W / 24 VA |
| Current consumption | Max. 1 A at 24 V |
| Protection category | IP 65 to EN 60 529/10.91 |
| Operating temperature | -10 ... +45 °C [+14 ... +113 °F] |
| Dimensions | 258 x 237 x 174 (W x H x D) |
| Weight | Approx. 2.5 kg |
| Interface | RS 485 (ModBus RTU), USB-Bus |
| Cable glands | 3 x M16 (4,5 - 10 mm Ø) |
| Screw terminals section | 0.2-2.5 mm ² [AWG 24-14] |
| Current output signal | 4 ... 20 mA (0 ... 20 mA), load < 500 Ω |
| Measurement value alarm relay output | Relay with switching contact Max. 250 V AC at 1 A |
| Data storage | Flash memory |
| Pulse output | Open Collector - max. 30 V, 20 mA |

| C-Box | |
|-------|-----------------------------|
| Size | 98 x 64 x 35 mm (W x H x D) |

