

FCI MT Series:

Multi-Point

Mass Flow Meters for



FCI MT SERIES

Gas or Air Service and

CEMS Stack Monitoring

FCI's MT Series Multi-Point Mass Flow Meters are ideal for today's most challenging industrial air or gas handling applications and continuous emissions monitoring systems (CEMS). Inside large combustion or preheater systems, HVAC units, ducts or flue stacks, MT Series multi-point flow meters measure flow with exceptional precision under variable thermodynamic conditions. They are an excellent choice for measuring mass flow almost anywhere variable conditions limit single-point flow meter effectiveness. Harsh environments, in which temperature, vibration, abrasion and corrosion pose difficulties for other meters, are no problem for the rugged MT Series multi-point flow meters. Instrument accuracy is available to $\pm 2\%$ of reading, with repeatability of $\pm 0.5\%$.

Key Product Performance Features

- › High accuracy – up to 16 flow sensing points per meter.
- › Diagnoses duct temperature stratification with dynamic temperature output capability.
- › Wide temperature range from -50°F to 850°F [-45°C to 454°C].
- › Pressures up to 50 psig [3,4 bar (g)].
- › Continuous built-in testing and calibration adjustment prevent drift for superior repeatability.
- › Averaging filter dampens response to rapid process fluctuations.
- › RS232C serial ports for communication with field devices.
- › Choose 4-20 mA, 1-5 Vdc or 0-10 Vdc outputs.
- › Menu-driven control for ease of service.

- › Rack mountable with card slots for expansion and option modules.
- › Stainless steel flow element construction; electronics enclosure rated NEMA/CSA Type 4.
- › Simple maintenance with modular design and interchangeable components.

MT86 and MT91 Series Multi-Point Flow Meters

The MT86 and MT91 Series flow meters are installed in thousands of applications worldwide. The MT91 Series flow meter is highly versatile, with a wide turndown range available (from 5:1 to 100:1) and flow sensitivity from 0.25 SFPS to 150 SFPS [0,08 NMPS to 46 NMPS]. With its smart digital flow transmitter and advanced thermal dispersion technology flow-sensing elements, the MT91 flow meter meets federal environmental requirements for CEMS per CFR Title 40, Part 75.

The MT86 and MT91 are multi-point flow meters with sensor arrays of up to 8 (MT86 unit) or 16 (MT91 unit) independent thermal flow sensors with a variable insertion length attached to a junction box and connected via cable to a remote electronics assembly. Individual flow sensors are placed along a support assembly to meet application-specific requirements. The flow element assembly for both the MT86 and MT91 flow meters is available with flanged, threaded or retractable process connections with a NEMA /CSA Type 4 junction box or optional explosion-proof flow element enclosure.





Dual sensing point flow element assembly with remote MT86 transmitter

The transmitter package for both the MT86 and MT91 flow meters also is housed in a NEMA/CSA Type 4 or optional explosionproof enclosure. The MT86 flow meter's electronics package is connected remotely by cable to the flow element assembly up to 500 ft [152 m] away, while the MT91 flow meter's electronics package is similarly connected up to 1000 ft [305 m] away. The MT91 flow meter's electronics package is also available in an optional 19-inch DIN or ANSI /EIA rack mount assembly.

Thermal Flow Sensing Element FCI's advanced flow sensing element design, based on thermal dispersion technology, measures air or gas mass flow with exceptional accuracy and repeatability over a wide range of temperatures and environmental conditions. Each all-metal flow element features a fouling immune no-moving-parts design for simple maintenance and long life. The flow element incorporates two platinum resistance-temperature detectors (RTDs) for temperature and flow measurement. All wetted surfaces are 316 stainless steel with nickel brazed joints per AMS 4777 (standard) or Hastelloy C-276 as an option. Coating materials, such as electroless nickel plating or chromium carbide are also available.

Mass flow rate is determined by the MT Series multi-point flow meter in the process stream by heating one of its RTDs while the other senses the temperature of the flowing media. The temperature differential between the RTDs relates to the

mass flow rate and properties of the process media. Higher flow rates or denser media, for example, cause increased cooling of the heated RTD and a reduction in the temperature differential.

Smart Flow Transmitter The MT91 flow transmitter features a powerful microprocessor-driven design for superior signal processing and data collection. The design includes a

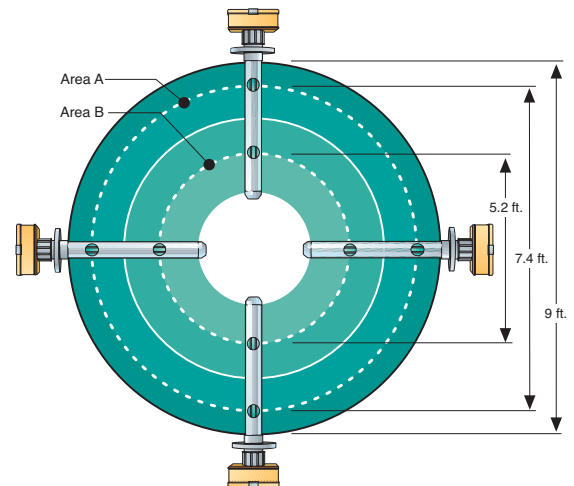

Equal-Area Sensing Point Placement

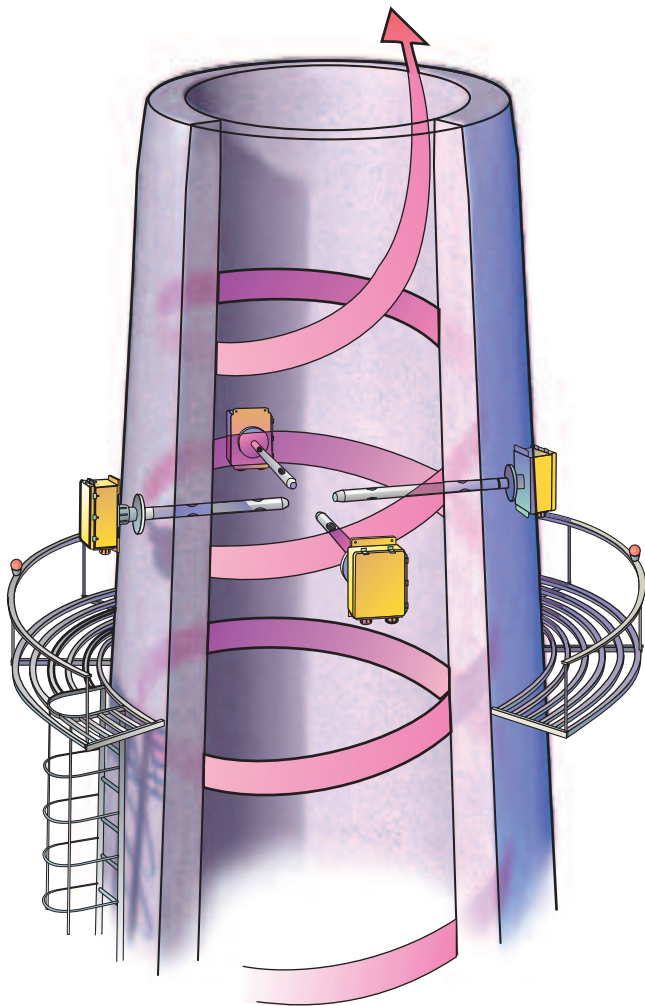

Typical Stack Installation

user-friendly menu-driven structure with LCD screen and keypad for programming the control, monitoring, display, and driver/ alarm functions. A nonvolatile EEPROM chip stores application and calibration data, and protects this data in the event of a power disturbance.

RS232C and HART communication ports offer easy links with controllers or other field devices. Signal outputs available are 4-20 mA, 1-5 Vdc or 0-10 Vdc. Other features include real-time temperature compensation, dynamic process temperature indication, built-in testing and self-diagnostics, dynamic conversion, display of application statistics and security safeguards against unauthorized access or tampering.

Typical Applications

- > Stack monitoring for Continuous Emissions Monitoring Systems (CEMS)
- > Primary air flow monitoring
- > Air flow monitoring for performance efficiency
- > Air monitoring to low NOX burners
- > Combustion air flow monitoring
- > Flue gas recirculation monitoring
- > Scrubber and precipitator balancing

- > Induced or forced draft fan monitoring
- > Preheater air to boilers or furnaces
- > Heavy-duty industrial HVAC

Multi-Point Versus Single-point Sensing | The unstable air currents and gases, often with particulates, that are found in large industrial facility ducts or flue stacks and in air or gas handling systems turn the task of mass flow measurement into a complex process. This task is often beyond the capabilities of single-point flow meters or differential pressure averaging devices.

As depicted in the accompanying illustration below, inaccurate flow rate readings can result when single-point metering instruments are used in ducts and stacks where large cross-sectional areas or limited straight-run lengths create irregular flow profiles.

Designed especially for such air/gas handling systems, the MT Series offers up to 16 sensing points which meter the mass flow rate of individual segments of the flow stream. Representing those rates, the signal outputs of each sensor element are summed by the instrument's control logic to provide an accurate reading of total mass flow rate through the entire duct.

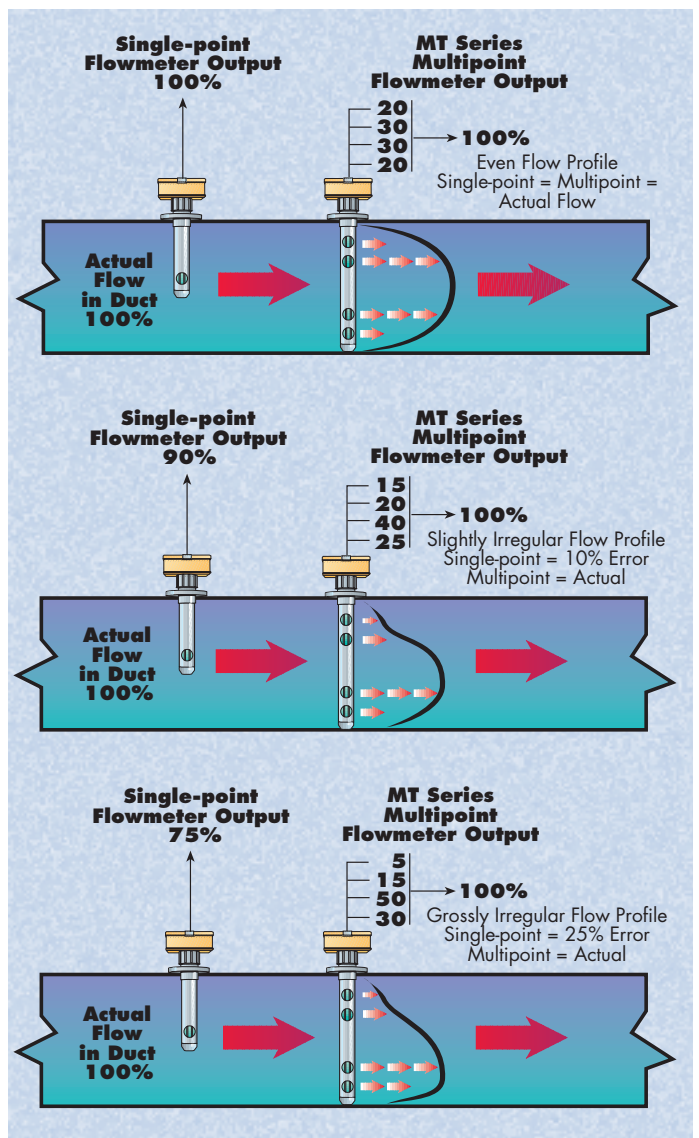

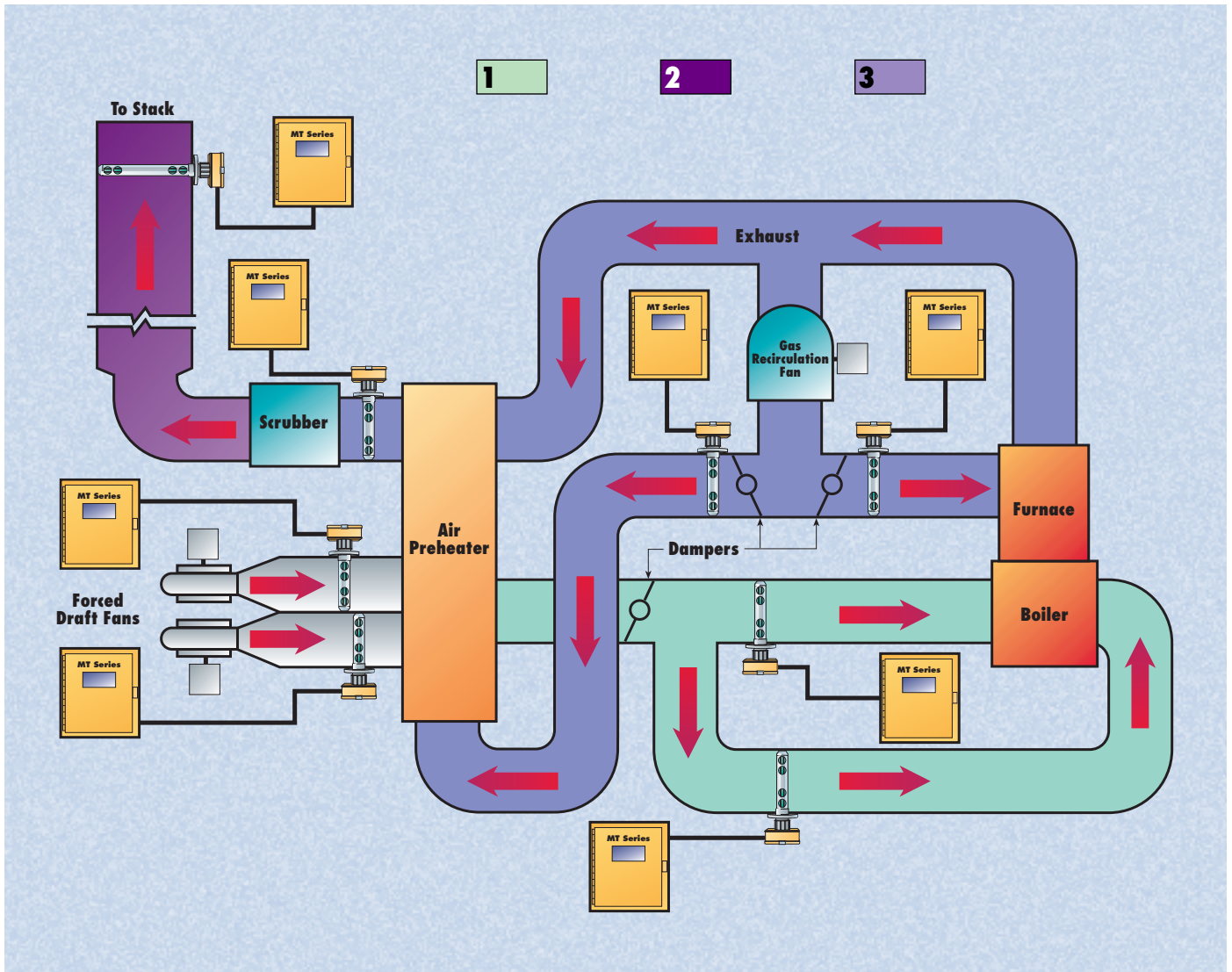

Improving the Efficiency of Industrial Air/Gas Systems with the MT Series Multi-Point Mass Flow Meters

1. Combustion Air and Preheater Air

To keep boilers, furnaces, and cogeneration units operating at maximum efficiency, individual combustion and preheater air flow feed lines are metered with the MT Series.

2. Stack Emissions

Reliable and accurate measurement of flow from effluent stacks in power, cogeneration, chemical, paper, refinery, and other industrial plants is critical to properly calculate total emissions. The MT Series can be used alone or in conjunction with environmental and/or radiation monitors for this purpose.

3. Flue Gas/Scrubber Balancing

Industrial pollution control systems can be operated far more effectively by utilizing the MT Series to meter and balance the flow of flue gas through scrubbers, precipitators and bag houses. Ultra-sensitive, the MT Series offers unsurpassed accuracy across broad flow ranges. The unit's low-profile, no-moving-parts design causes virtually no pressure drop in large lines, and the optional abrasion-resistant probe coating provides outstanding protection against fly ash and other particulate matter.

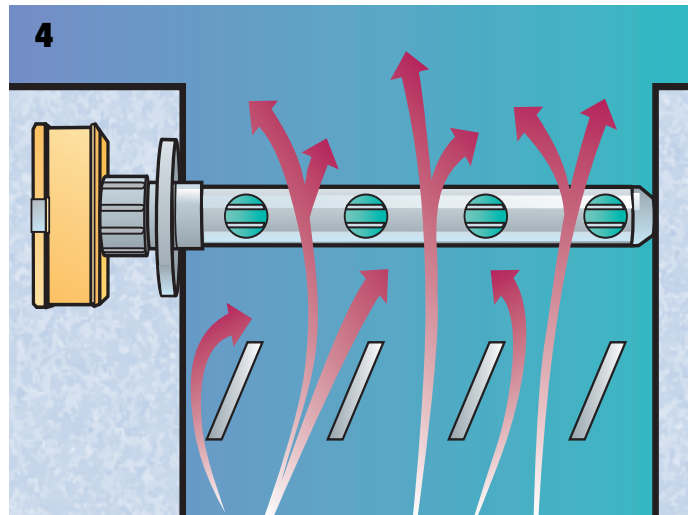

4. Heating, Ventilation & Air Conditioning

Ultra-low flow sensitivity, wide turndown and easy duct mounting make the MT Series the choice for HVAC flow metering. Accurate at the low flow rates typical in such systems, the MT Series not only measures and totals air flow, it can also be used for controlling louvers to balance flow within the system.

Remote MT91 Transmitter Assembly -- NEMA/CSA Type 4 and Explosion Proof

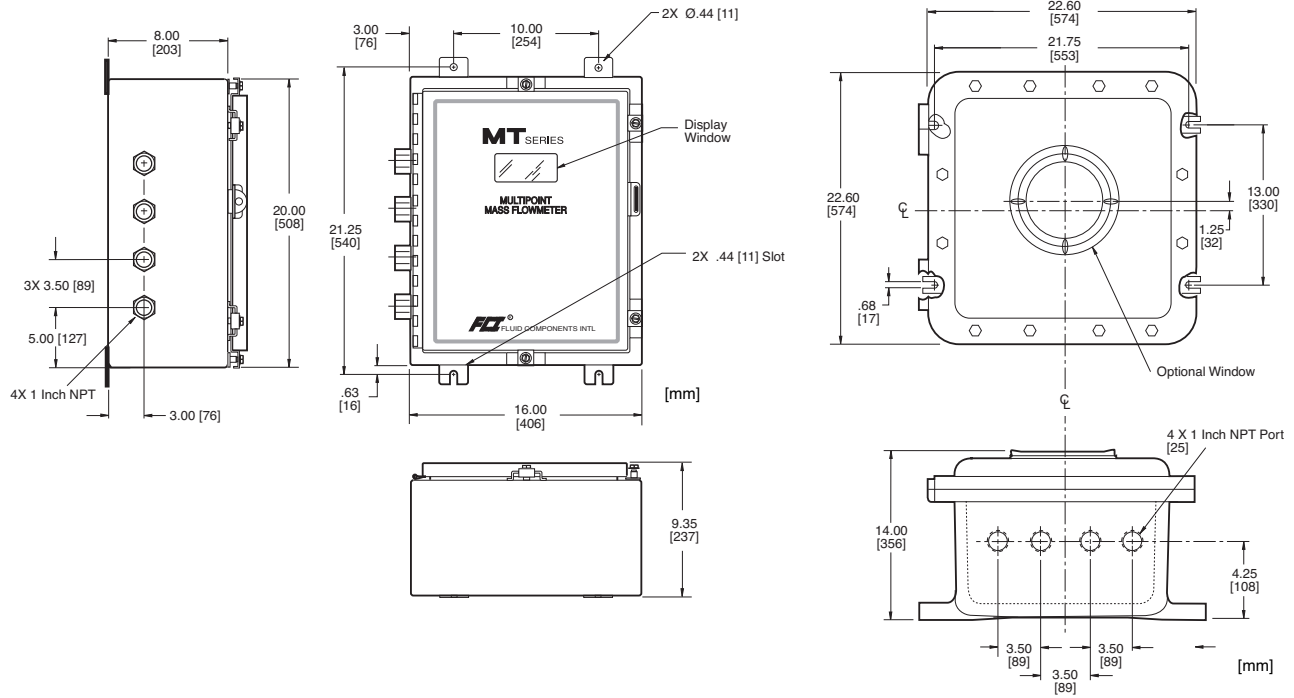

Remote MT91 Transmitter - Rack Mount

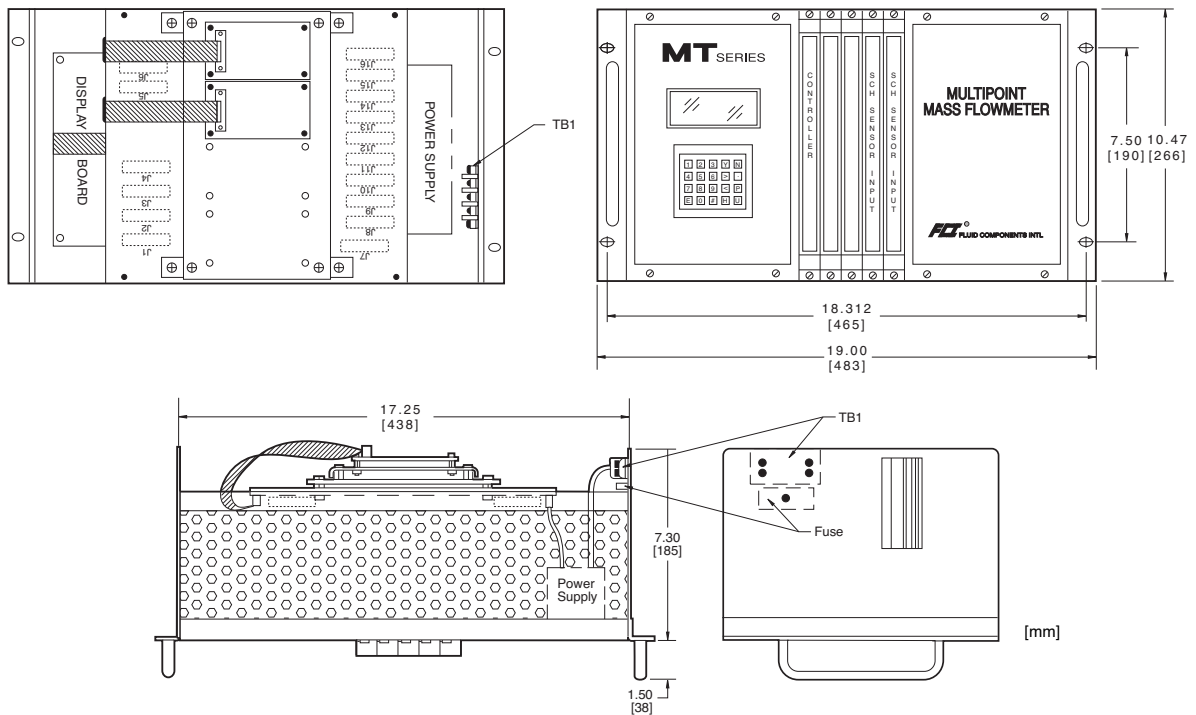

MT Series Flow Element Assembly – NEMA/CSA Type 4

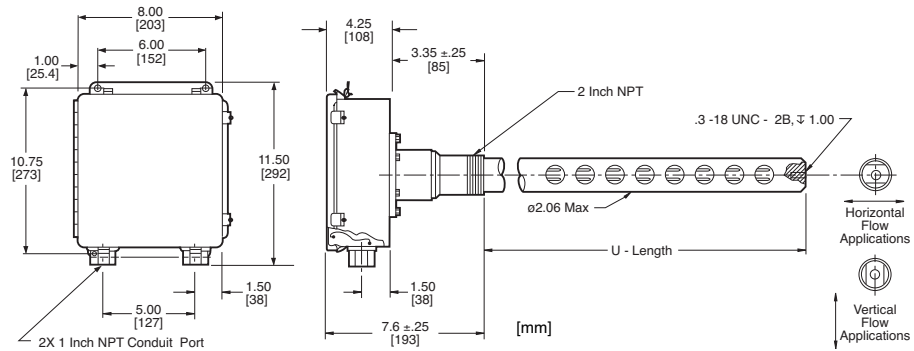

MT Series Flow Element Assembly – Explosion Proof

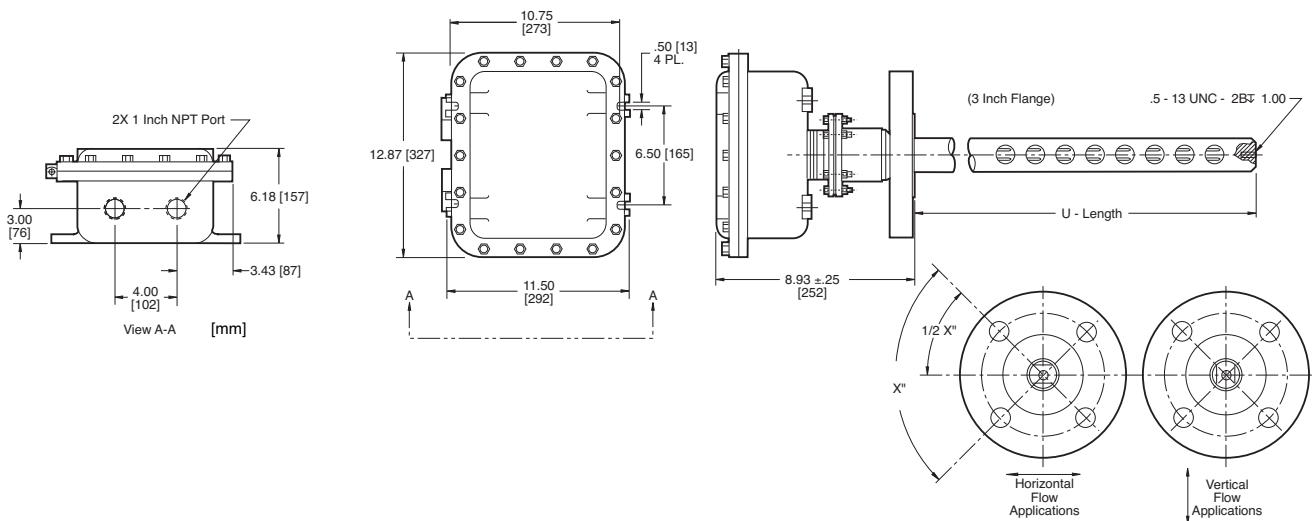

Remote MT86 Transmitter Assembly – NEMA/CSA Type 4 and Explosion Proof

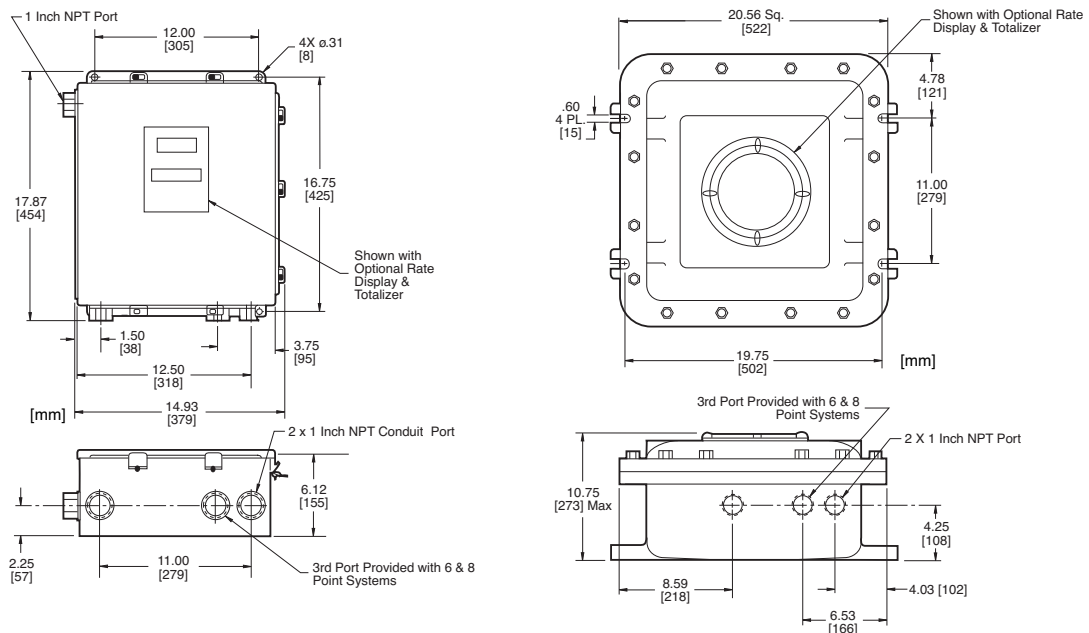

MT86 and MT91 Multi-Point Mass Flow Meter Specifications

Flow Element

Process Connection: 2 inch male NPT or 3 inch, 150 lb. raised face carbon steel flange. Other flange sizes and materials available.

Insertion Length: Variable insertion lengths; customer specified.

Materials of Construction: All wetted surfaces are 316 stainless steel nickel brazed per process specification AMS 4777. Hastelloy C-276 is also available. Electroless nickel or chromium carbide plating is also available.

Number of Sensing Points per System: Up to 8 points, total.

Flow Range: 0.25 SFPS to 150 SFPS [0.08 NMPS to 46 NMPS] in air at standard conditions of 70 °F and 14.7 psia [20 °C and 1.013 bar (a)]. Consult factory or manufacturer's representative for application information pertaining to gases other than air.

Enclosure: NEMA/CSA Type 4 and equivalent to IP66, optional explosion-proof, groups B, C, D - Divisions 1 and 2.

Operating Temperature:

Standard: -50 °F to 350 °F [-45 °C to 177 °C]

Optional: -50 °F to 850 °F [-45 °C to 454 °C]

Operating Pressure: To 50 psig [3,4 bar (g)]

Design Pressure: To 500 psig [34 bar (g)]

Transmitter

> MT86

Analog Outputs:

Standard (*1 output*): 4-20 mA, 1000 Watts maximum

Optional (*up to 4 outputs*): 10-50 mA, 400 Watts maximum

0-5 Vdc, 2 mA maximum

1-5 Vdc, 2 mA maximum

0-10 Vdc, 2 mA maximum

Relay Outputs: Dual DPDT alarm: 2 amp contact rating optional.

Input Power:

Standard: 115 Vac, 50/60 Hz, 50 Watts maximum, 1/2 amp fuse

Optional: 230 Vac, 50/60 Hz, 50 Watts maximum, 1/4 amp fuse

100 Vac, 50/60 Hz, 50 Watts maximum, 1/2 amp fuse

24 Vdc, 1.5 amp fuse

Enclosure: Remote NEMA/CSA Type 4 and equivalent to IP66. Explosion-proof optional.

Conduit Connection: 1 inch female NPT

LCD Display: Optional

Operating Temperature:

Without LCD Display: -50 °F to 150 °F [-45 °C to +66 °C];

With LCD Display: 0 °F to 150 °F [-18 °C to 66 °C]

Accuracy: ± 2% rdg, ± 0.5% full scale.

Repeatability: ± 1% of reading.

Turndown: 5:1 to 100:1 maximum

Transmitter

> MT91

Analog Outputs: Dual module, field programmable for flow or temperature outputs configured as:

4-20 mA into a maximum of 600 Watts, or

0-10 Volts into a minimum of 5000 Watts, or

1-5 Volts into a minimum of 2500 Watts

Relay Outputs: Dual DPDT alarm: 2 amp contact rating. Field programmable for flow, temperature, or sensing point fault.

Input Power: 85 Vac to 265 Vac, 47 Hz to 63 Hz, 3.5 amp fused; 20 Vdc to 32 Vdc, 24 Vdc nominal. Consult factory for special power requirements.

Enclosure: Remote NEMA/CSA Type 4 and equivalent to IP66 electrical enclosure. Optional 19 inch rack in accordance with DIN 41494 part 1, ANSI/EIA-RS-310C.

Conduit Connection: 1 inch female NPT.

Communication Port: RS-232C or HART.

Operating Temperature:

With local display: 32 °F to 140 °F [0 °C to 60 °C]

Without local display: 0 °F to 140 °F [-18 °C to 60 °C]

LCD Display: 4 lines by 20 characters/line. Menu driven system prompts the user for system commands.

Keypad: 20 keys provide easy touch programming for changing zero, span, switch points, units of measure, etc.

Flow Accuracy:

For ± 30 °F [± 17 °C] range: ± 2% reading or ± 0.2 SFPS [± 0.06 NMPS]

For over ± 100 °F [± 55 °C] range: ± 4% reading or ± 0.5 SFPS [± 0.15 NMPS]

Flow Repeatability: ± 0.5% reading.

Turndown: 5:1 to 100:1 maximum.

Stated flow performance from 1 SFPS to 100 SFPS [0.3 NMPS to 30 NMPS].

Contact factory for accuracy in applications beyond this flow range.

Temperature Output Accuracy:

For 32 °F to 212 °F [0 °C to 100 °C]: ± 0.9 °F [± 0.5 °C]

For < 32 °F [0 °C] and/or > 212 °F [100 °C]: ± 1.8 °F [± 1 °C]

Temperature Output Repeatability:

For 32 °F to 212 °F [0 °C to 100 °C]: ± 0.2% reading

For < 32 °F [0 °C] and/or > 212 °F [100 °C]: ± 0.5% reading

Stated temperature performance at a minimum flow rate of 5 SFPS [1.5 NMPS]. Contact factory for accuracy of temperature indication when flow rate is below 5 SFPS [1.5 NMPS].

Calibration – MT86 and MT91

Performed on NIST traceable equipment.



Repres

Representantes / Distribuidores Exclusivos

Buenos Aires, Argentina

Tel.: (54 - 11) 5352-2500

Email: info@dastecsrl.com.ar

Web: www.dastecsrl.com.ar



Tel: (+54 11) 5352 2500

Email: info@dastecsrl.com.ar

Web: www.dastecsrl.com.ar



Uruguay www.dastecsrl.com.uy



Bolivia www.tecdas.com.bo